

**Final Written Examination.**

29/12/2013



Time all : 3 Hrs

Answer the following questions

Question one: Choose the best answer: (YOU CAN SELECT MORE THAN ONE ANSWER)  
[10 Marks]

1) *Electrosurgery machines do not cause VF because the current they deliver differs from the electric current supplied by wall electrical outlets primarily by being :*

- a) DC instead of AC
- b) Lower in voltage
- c) Lower in frequency
- d) Higher in frequency**

2) *Earth Leakage Current is current that:*

- a) passes to earth through the operator
- b) passes to earth through the patient
- c) flows down the earth wire of the equipment**
- d) any combination of the above

3) *Which of the following situations is NOT a fault condition*

- a) external voltage on the applied part
- b) mains polarity reversed**
- c) patient accidentally touching earth**

4) *For Electrical Safety Analyzers (as shown) , in case of "open ground" ,which LED will be on ?*

- a) LED 1**
- b) LED 2**
- c) LED 3**
- d) NO LEDS

5) *In case of hot /neutral reversed, which LED will be on?*

- a) LED 1
- b) LED 2**
- c) LED 3**
- d) NO LEDS

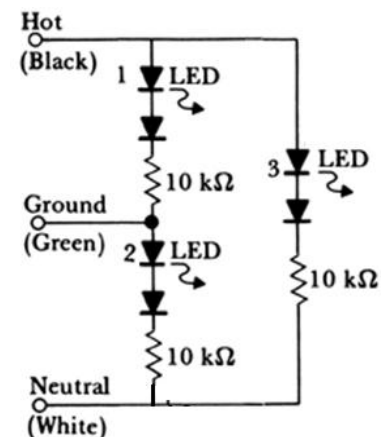

**Question two: Complete: [10 Marks]**

1. Step potential is the voltage **between the feet of a person standing near an energized grounded object.** & Touch potential is the voltage **between the energized object and the feet of a person in contact with the object .**
2. The **primary** goal of the grounding system throughout any facilities is **personnel safety** & the **second** goal is **equipment protection** protection.
3. The fundamental methods that used in the design of isolation amplifiers are **Transformer Isolation, Optical Isolation & Capacitive Isolation** with the peak isolation voltage of **1 to 10 kV** without breakdown.
4. Receptacles should be tested for **proper wiring, adequate line voltage, low ground resistance & mechanical tension.**
5. IEC is **International Electrotechnical Committee**, NEC is **National Electric Code** NFPA is **National Fire Protection Association** & ANSI is **American National Standards Institute.**

**Question Three: Answer the following question in brief**

- a) Describe the difference between macroshock and microshock

Electrical shock involves electrical stimulation of tissue and its effects range from a tingling sensation to violent reaction of muscles tetanus to ventricular fibrillation

**Macroshock :** externally applied current spread throughout the body ( min. value for safe 0.5 mA)

**Macroshock :** a high value current level(mA) which passes arm to arm throughout the body by (skin) contact with a voltage source

**Microshock :** a low level current ( $\mu\text{A}$ ) which passes directly through the heart via a needle or catheter (bad effect  $> 10 \mu\text{A}$ )

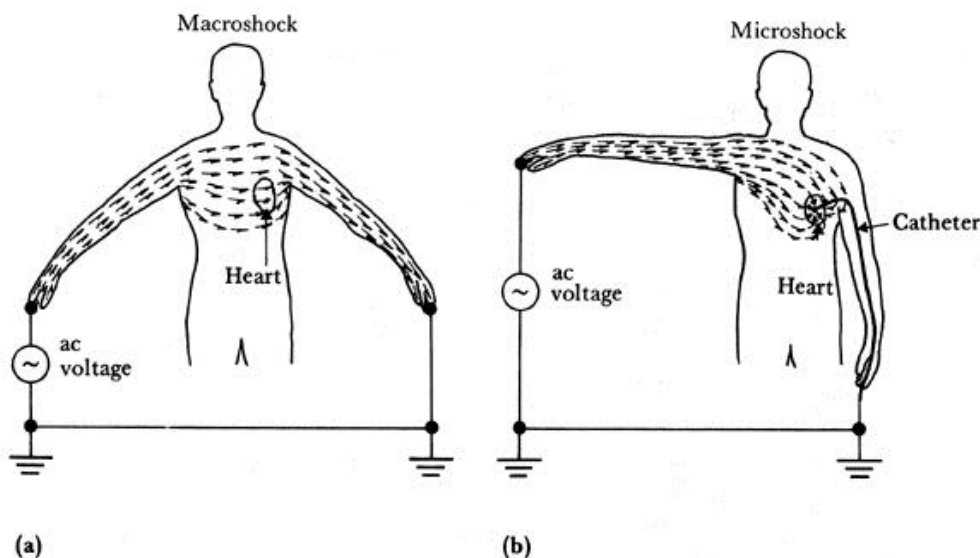

b) Explain the chemical rod for grounding system and list its disadvantages.

- Chemical rods are electrodes with holes along their length, filled with mineral salts.
- The specially formulated mineral salts are evenly distributed along the entire length of the electrode.
- The rod absorbs moisture from both air and soil.
- Continuous conditioning of a large area insures an ultra-low-resistance ground which is more effective than a conventional electrode.
- If the conductive salts are running low, the rod can be recharged with a refill kit.
- These rods are available in vertical and horizontal configurations.
- They may be used in rocky soils, freezing climates, dry deserts, or tropical rain forests.
- They provide stable protection for many years.

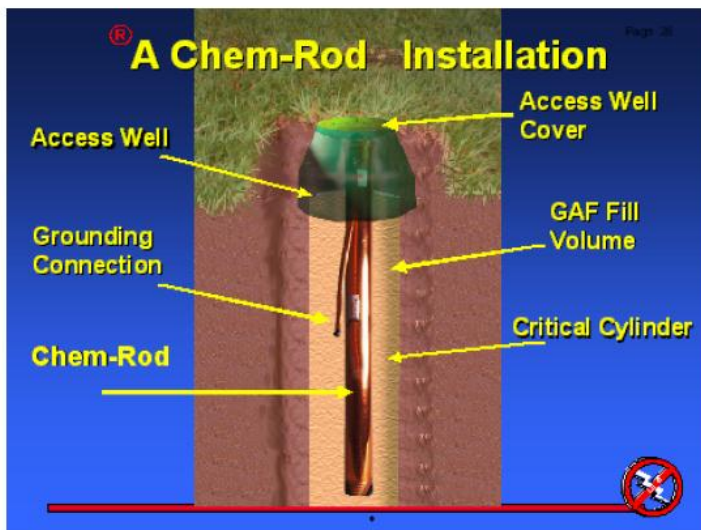

Figure 1. Chemically Charged Ground Rod

**Disadvantages are:**

- Chemicals concentrated around electrodes will cause corrosion
- Chemicals leach through the soil and dissipate
- Scheduled replacement may be required
- May be prohibited because they may contaminate the water table

c) List the physiological effects of electricity on human body

- Threshold of perception
- Let-go current
- Respiratory Paralysis / Pain / Fatigue
- Ventricular fibrillation
- Sustained myocardial contraction / Burns and physical injury

d) "Potentially most damaging leakage is the one with patient leads, since they typically have low impedance patient contacts, current should be restricted to  $50\mu\text{A}$  for non-isolated leads and to  $10\mu\text{A}$  for isolated leads". What does isolated and non-isolated mean? Explain with drawing the possible tests for leakage current in patient leads to ground.

- Leakage current in patient leads is particularly important because these leads are the most common low-impedance patient contacts.
- Current should be restricted to  $50\mu\text{A}$  for non-isolated leads and to  $10\mu\text{A}$  for isolated leads (used with catheters / electrodes that make connection to the heart)

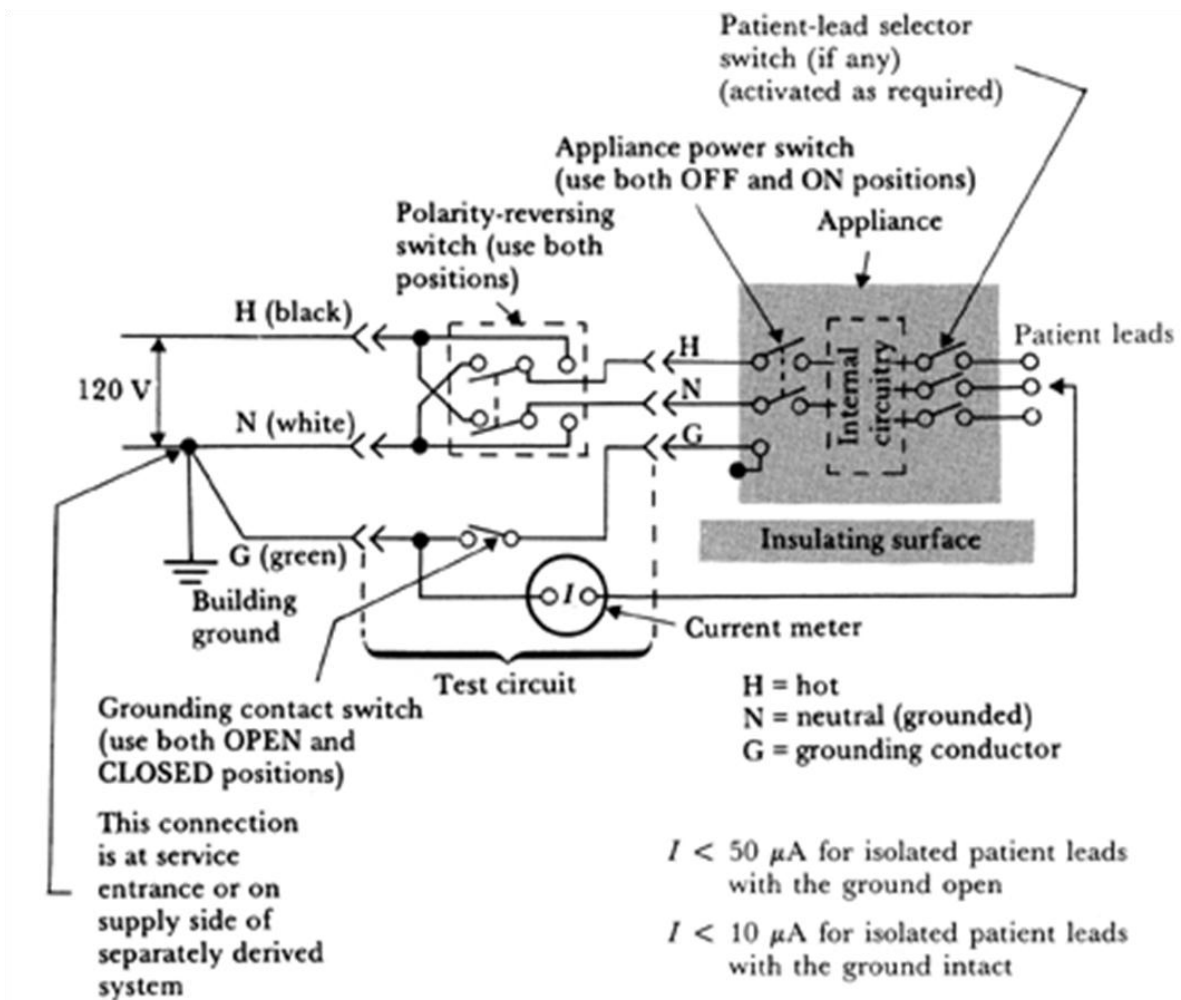

**Question four:**

- a) Design with drawing a complete power and grounding systems for ICU that consists of many instruments such as ( ECG, EEG, Defibrillator & Saline-filled catheter )
- b) Design the rod for grounding system to prevent patient shock If the soil resistivity is 20  $\Omega \cdot m$

$$R = \frac{\rho}{2\pi l} \left[ \ln\left(\frac{8l}{d}\right) - 1 \right]$$

- where:  $\rho$  Soil Resistivity in  $m$   
 $l$  Buried Length of the electrode in  $m$   
 $d$  Diameter of the electrode in  $m$

$$0.5 = \frac{20}{2\pi l} \left[ \ln\left(\frac{8l}{d}\right) - 1 \right]$$

- c) If one line from the isolation transformer shorts one chassis, and the other line from the isolation transformer shorts to another chassis, and both have broken ground wires, will the line isolation monitor indicate a fault? Explain.

**The line isolation monitor will indicate no fault, but a severe electrocution hazard exists.**

**Question Five:**

- a) Draw a complete equivalent circuit and compute the RMS current through the patient's heart for the following situation. The patient's hand touches a faulty metal lamp that is 120Vrms above ground. A saline-filled catheter ( $R=50K\Omega$ ) for measuring blood pressure is connected to the patient's heart. Some of the pressure-transducer strain-gage wiring is grounded, and the transducer is somewhat isolated electrically. However, there is  $20M\Omega$  of leakage resistance in the insulation between the ground and the saline in the transducer. There is also 100pf of capacitance between the ground and the saline. Assume that the skin resistance of the patient is  $1M\Omega$ . Is there a microshok hazard?

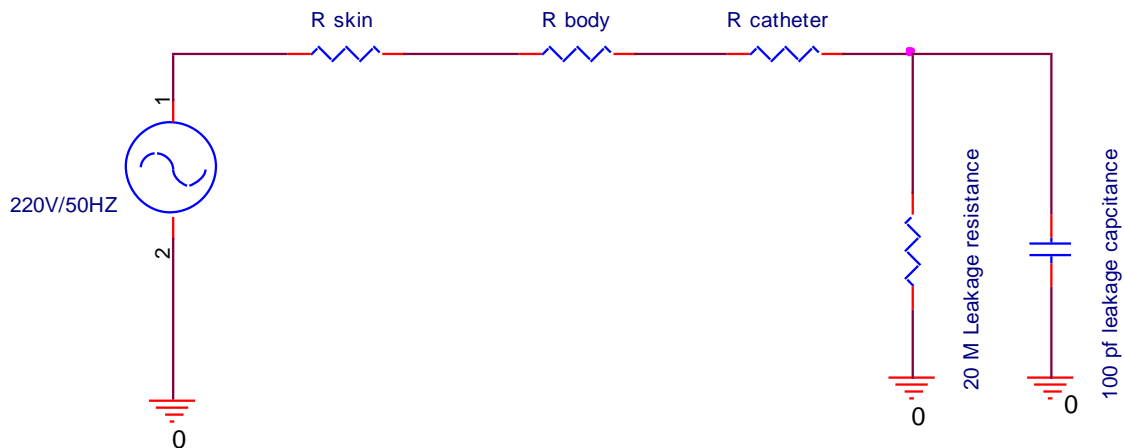

Take  $R_{\text{body}} = 200\Omega$  (or it may be neglected)

$$Z_p = 16934659.79 \Omega = 16.935 \text{ M}\Omega$$

$$I = V/Z$$

$$I = 220 / [(1 \cdot 10^6) + (200) + (50 \cdot 10^3) + (16.935 \cdot 10^6)] = 12.336919 \mu\text{A} > 10 \mu\text{A} \text{ There is a microshock hazard}$$

b) If the patient is being monitored by an ECG monitor that grounds the right leg electrode and the patient's arterial pressure is being monitored using an intracardiac saline filled catheter connected to a pressure transducer, which attaches to the pressure monitor case and then to ground. These monitors are connected to the same grounded three-wire wall receptacles. Let us assume that a cleaning service person now plugs a vacuum cleaner into a wall outlet on the same circuit as the ECG monitor. The cleaner has a three-wire power cord with a third broken grounding wire. The windings of the motor are continually exposed to dust, often damp, which provides a good path for an eventual "winding-to-outer-case" short, assume the short circuit current is about 10 A, and the grounding resistance of  $0.1 \Omega$ . If the patient's resistance as  $150 \Omega$  and the differential voltage between the saline filled and right leg as  $0.5 \text{ mV}$ . Draw the situation and find the current flowing through the patient. Is the patient in danger???

**Answer**

- Because the ground wire is broken then no return current to earth ,this mean no voltage drop in patient during short circuit current
- Because the ECG & saline filled connected to the same ground then the differential voltage between the saline filled and right leg has no effect in patient
- The voltage in patient equal zero ,then the patient is safe

