



Radio and Television (E522)

Model Answer

No. of Questions: 3

Question (1)

(20 Marks)

- a. What is the difference between receiver sensitivity and selectivity? Describe the difficulties in listening to an AM receiver without AGC? (3 marks)

Sensitivity

The minimum input signal voltage required to produce an acceptable output level.

Selectivity

The extent to which a receiver is capable of differentiating between the desired signal and disturbances at other frequencies (unwanted radio signal and noise)

Without AGC we have to regularly control the volume while switching from one station to another.

- b. A superheterodyne receiver tuned to 1.3 MHz has the following specifications:

RF Amplifier: $P_G = 5.5$ dB, $R_{in} = 50 \Omega$, ***Detector:*** 4 dB attenuation

Mixer: $P_G = 2.5$ dB, ***Audio amplifier:*** $P_G = 10$ dB and ***3 IFs:*** $P_G = 20$ dB each at 455 kHz

The antenna delivers a 21 μ V signal to the RF amplifier. Calculate the receiver's image frequency and input/output power in watts and dBm. Draw a block diagram of the receiver and label dBm power through. (4 marks)

Answer

Receiver image frequency = $1.3 \text{ MHz} + 2(455 \text{ kHz}) = 2.21 \text{ MHz}$

Input Power = $V^2/R_{in} = (21 \mu\text{V})^2/50 = 8.82 \text{ pW}$

Input Power (dBm) = $10 \log (8.82 \text{ pW}/1 \text{ mW}) = -80.5 \text{ dBm}$

Output Power = $-80.5 \text{ dBm} + 5.5 \text{ dB} + 2.5 \text{ dB} - 4 \text{ dB} + 3 \times 20 \text{ dB} + 10 \text{ dB} = -6.5 \text{ dBm}$
 $\rightarrow 0.224 \text{ mW}$

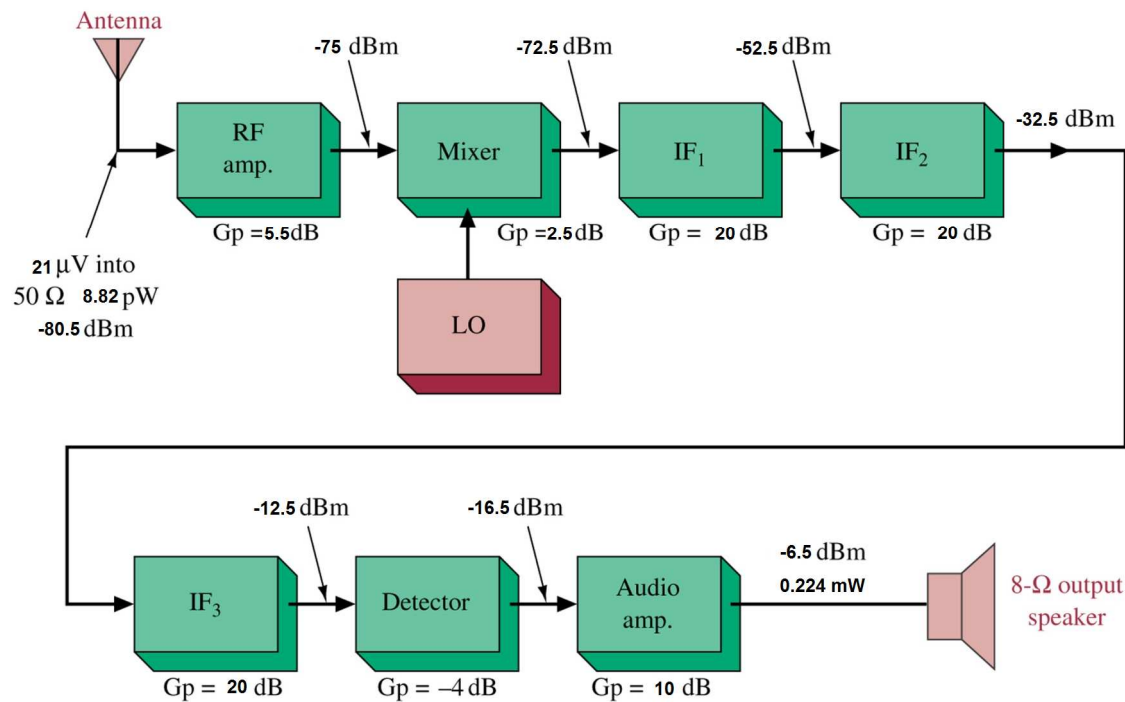

- c. Draw a diagram of the slope detector and explain its principle of operation. What is the main disadvantage of such circuit? Name other two alternative circuit solutions. (4 marks)

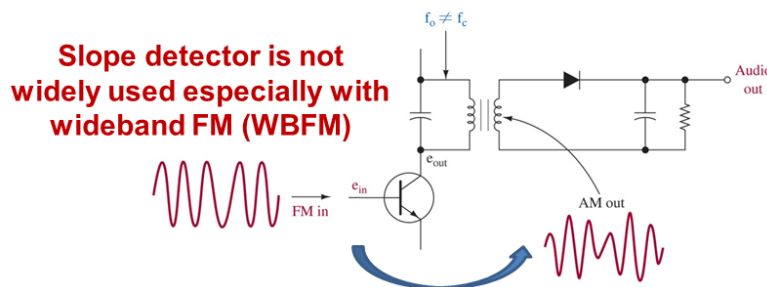
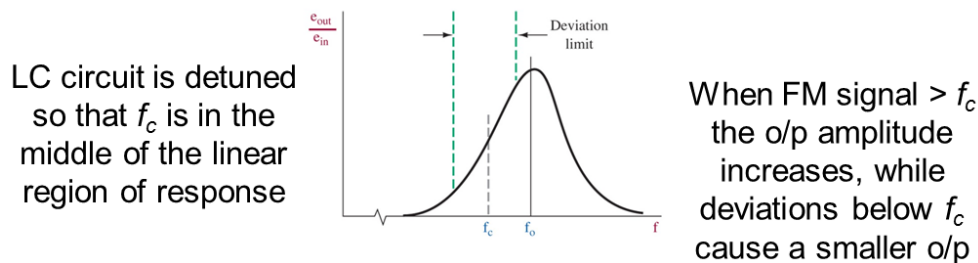

- Slope detector is an easiest FM discriminator
- A tuned circuit which is tuned so that the carrier frequency of the FM signal is in a linear region of the filter edges
- Thus turning FM into AM that can be recovered with a diode detector

The main disadvantage

- Slope Detector has small linear response which is not suitable for detecting WBFM

Alternative Circuits

- Foster-Seely Discriminator
- Ratio Detector

d. For a PLL, a VCO natural frequency, $f_n = 200$ KHz, an external input frequency, $f_i = 210$ KHz, and the transfer functions $K_d = 0.2$ V/rad, $K_f = 1$, $K_a = 5$, and $K_o = 20$ KHz, determine: (5 marks)

1. PLL open-loop gain in Hz/rad and rad/s.
2. PLL output voltage (V_{out}).
3. Static phase error (θ_e).
4. Hold-in range (Δf_{max}).

$$K_L = \frac{0.2V \cdot 1V \cdot 5V \cdot 20KHz}{(rad)(volt)(volt)(volt)} = \frac{20 KHz}{rad}$$

$$K_v = 2\pi K_L = \frac{20KHz}{rad} = \frac{20 \text{ kilo cycles}}{rad \cdot s} \times \frac{2\pi \text{ rads}}{\text{cycle}} = 125,600 \frac{rad}{s}$$

$$K_{v(dB)} = 20 \log 125,600 = 102 \text{ dB}$$

$$\Delta f = f_i - f_n = 210 \text{ KHz} - 200 \text{ KHz} = 10 \text{ KHz}$$

$$V_{out} = \frac{\Delta f}{K_o} = \frac{10 \text{ KHz}}{20 \text{ KHz/V}} = 0.5 \text{ V}$$

$$V_d = \frac{V_{out}}{K_f K_a} = \frac{0.5}{(1)(5)} = 0.1 \text{ V}$$

$$\theta_e = \frac{V_d}{K_d} = \frac{0.1 \text{ V}}{0.2 \text{ V/rad}} = 0.5 \text{ rad or } 28.65^\circ$$

$$\Delta f_{max} = \frac{(\pm \frac{\pi}{2} \text{ rad})(20 \text{ KHz})}{rad} = \pm 31.4 \text{ KHz}$$

e. Draw the block diagram of a typical FM monophonic and stereo broadcast receiver and show its signal processing part. Draw the antenna input frequency spectrum. (4 marks)

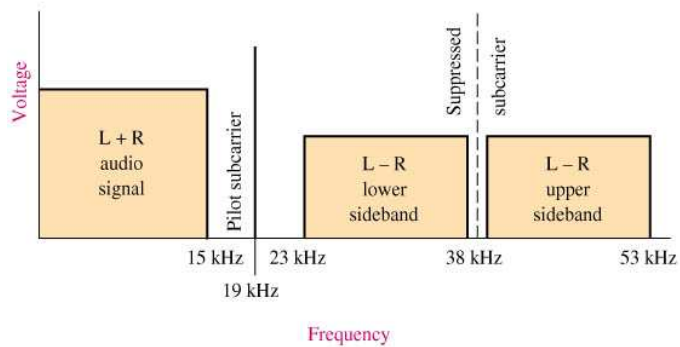
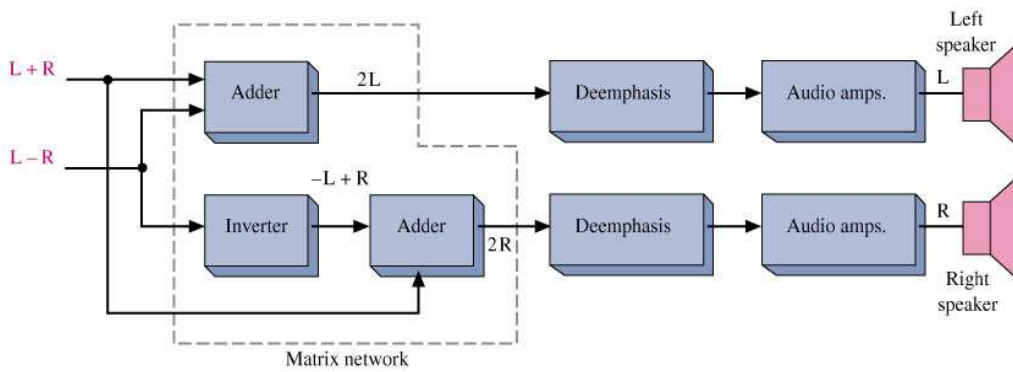
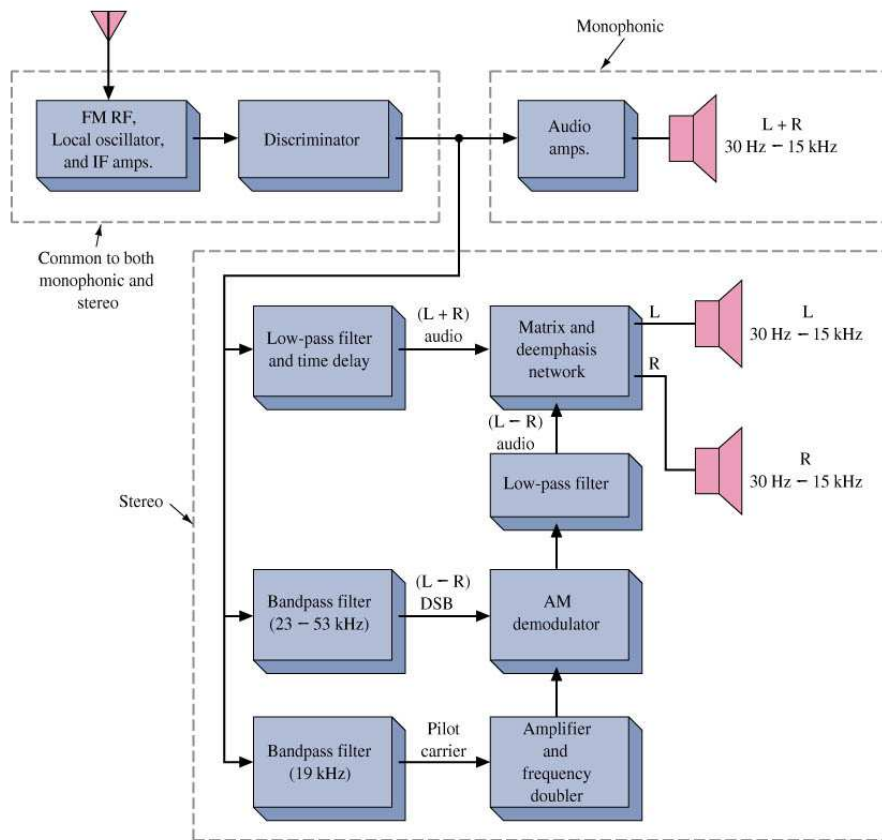

Question (2)

(22 Marks)

- a. Why is a diplexer a necessary stage of most TV transmitters? Why is interlacing used in television broadcasting? (2 marks)
- Diplexer combines the AM modulated video signal with the FM modulated sound signal for feeding to the antenna. It does not allow the two transmitters to interfere with each other 'fed back into the other transmitter'.
 - 30 frame/second is not enough to keep the human eye from perceiving flicker → noncontinuous visual presentation. If the frame frequency is doubled → no flicker. However, the video signal bandwidth have to be doubled. *Interlaced scanning* is used to trick the human eye into thinking that it is seeing 60 pictures/second
- b. Draw only the block diagram of TV receiver. What is the purpose of synchronization pulses of TV transmitted signal? Draw the horizontal synchronization pulse of TV transmitted signal. (5 marks)

Block diagram of TV receiver

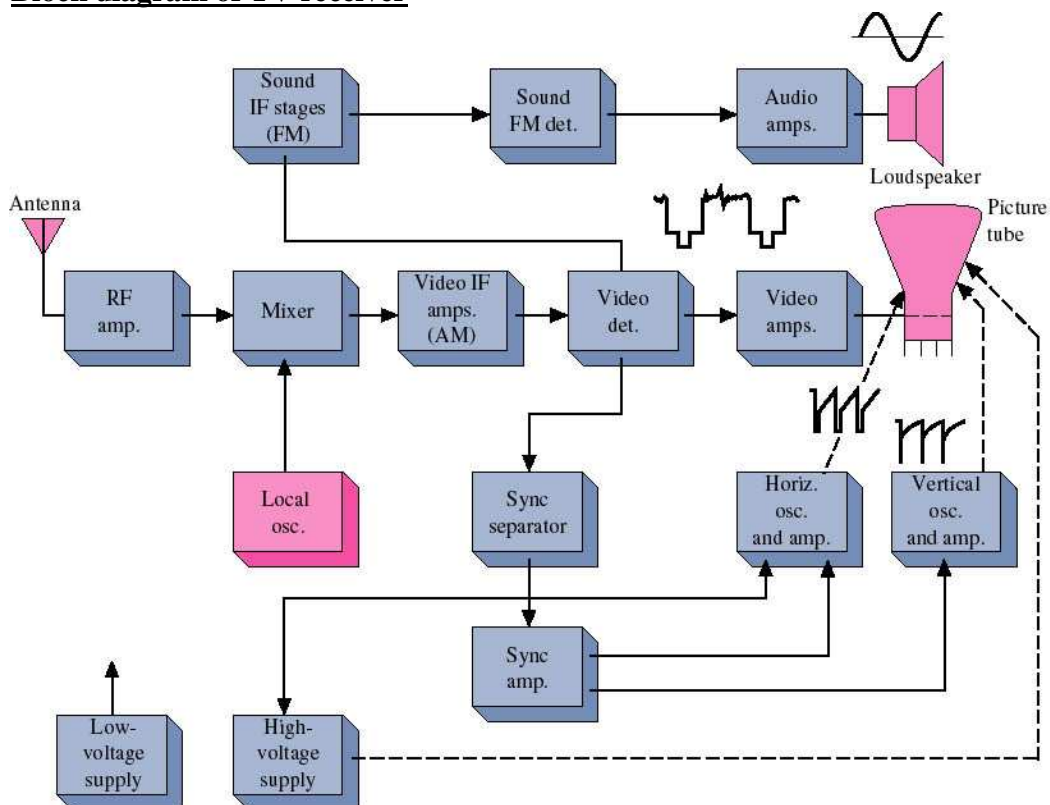

Synchronization pulses is used to set the speed that the transmitter scans each line to be exactly duplicated by the receiver scanning process to avoid distortion.

Horizontal Sync Pulses

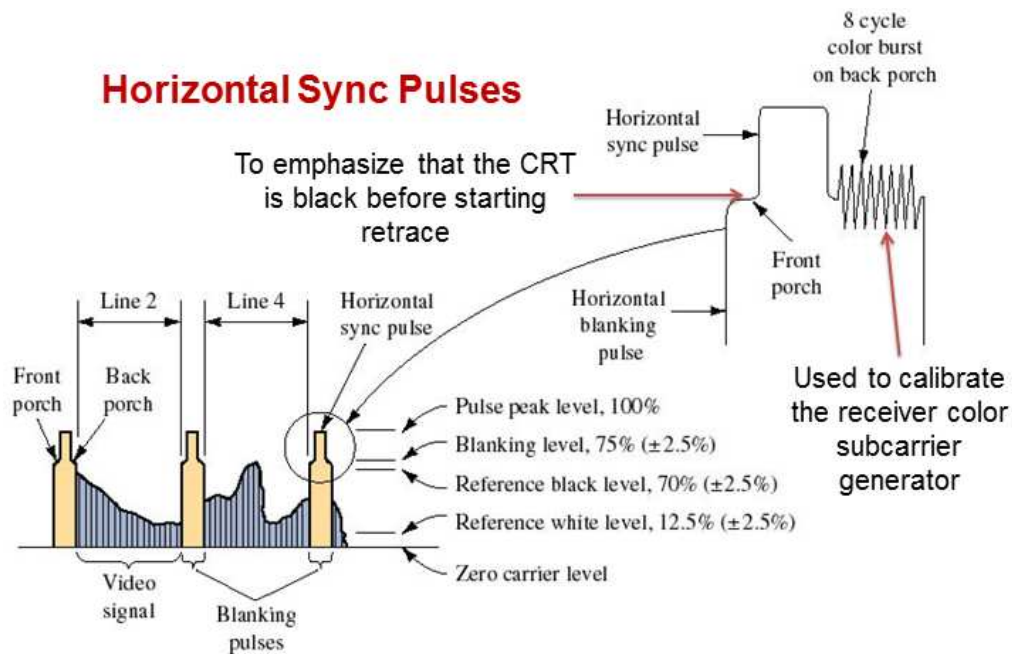

- c. Calculate the frequency required for the horizontal and vertical Sync pulses? If $10 \mu\text{s}$ is left for the blanking period, determine the decrease in horizontal resolution of TV transmitter if the video bandwidth frequency is decreased from 4 MHz to 3.5 MHz. (3 marks)

Answer:

- The vertical retrace (sync) pulses must occur after each $1/60$ second
The frequency of the vertical f_V sync pulses 60 Hz

Horizontal sync pulses occur once for each of the 525 lines every $1/30$ seconds
The frequency of the horizontal f_H sync pulses $525 \times 30 = 15.75 \text{ kHz}$

- Line Duration = $1/\text{Line Frequency} = 1/15.75 \text{ kHz} = 63.5 \mu\text{s}$
Each line lasts 63.5 ms with 10 ms for the blanking period leaving 53.5 μs
The total number of horizontal lines resolvable is $53.5 \mu\text{s} \times 4 \text{ MHz} \times 2 = 428$ lines

- d. If a television broadcast station transmits the video signals on channel 5 (76 to 82 MHz), what is the center frequency of the aural transmitter. Draw a detailed spectrum of the input and output signal of the mixer stage. (3 marks)

Answer: The center frequency of the aural carrier is $76 + 5.75 = 81.75 \text{ MHz}$

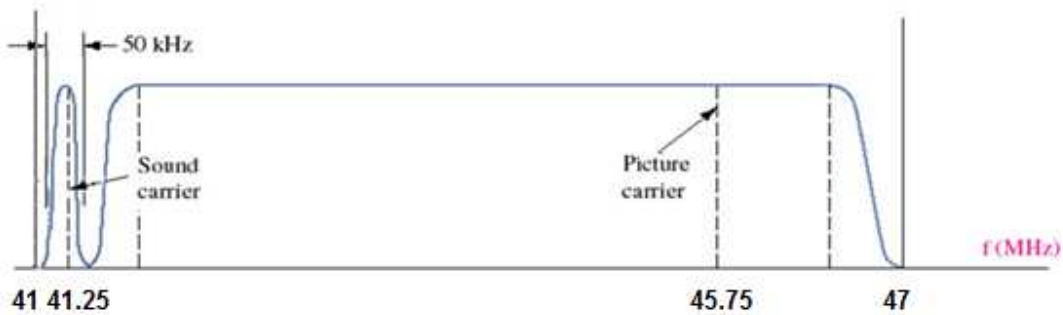
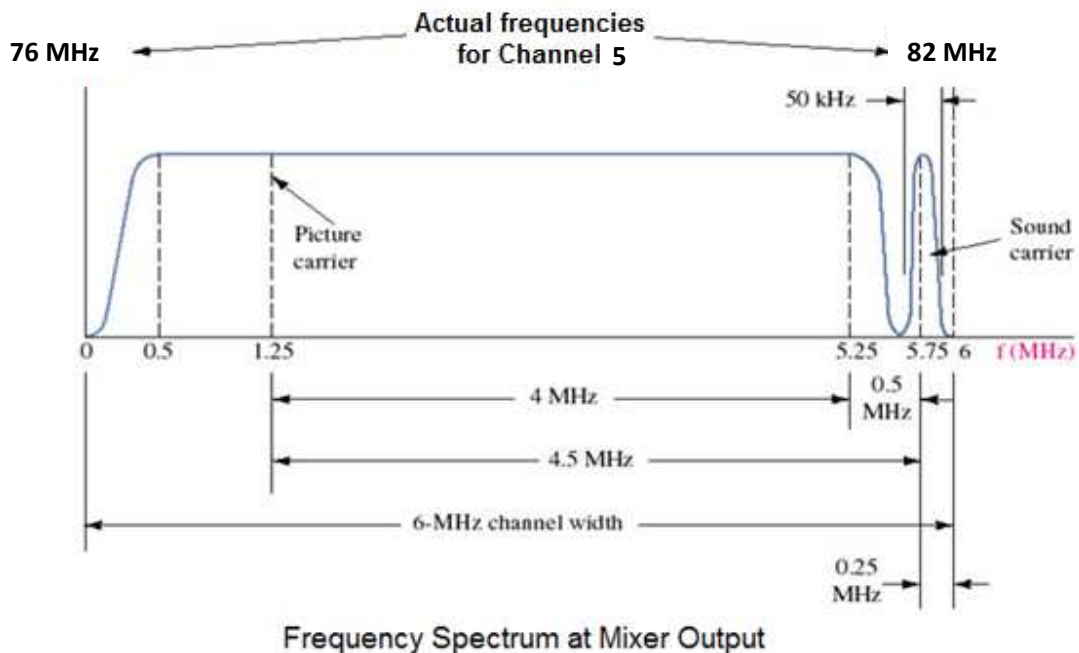

e. Explain why stagger tuning is often used in TV IF amplifiers. What is the function of the sync separator and what types of circuits are used for such purpose? (3 marks)

- **stagger tuning** is used to get a relatively wide bandwidth filter (6 MHz) which is reasonably flat in the passband but still has sharp falloff at the band edges. It uses several narrowband filters in cascade with slightly different centre frequencies.

- The sync separator

- Separates the horizontal and vertical sync pulses, and use them to precisely and periodically calibrate the horizontal and vertical oscillators
- Clips the sync pulses off the video signal to prevent the sweep instability that could occur because of false synchronization

- Once the sync separator has clipped the sync signals from the lower-level video signal, the two types of sync pulses are applied to both low and high pass filters

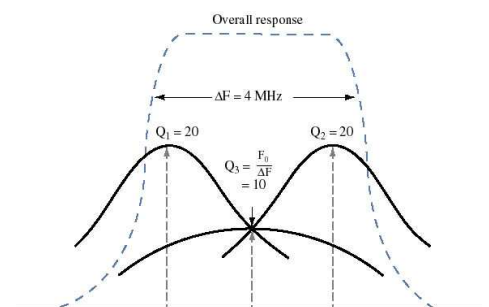

- f. Draw a block diagram of the quadrature modulation part in a color TV transmitter. Show the frequency spectrum of the composite color TV transmission. Explain the operation of the color killer. Describe the effect of a defective color killer. (6 marks)

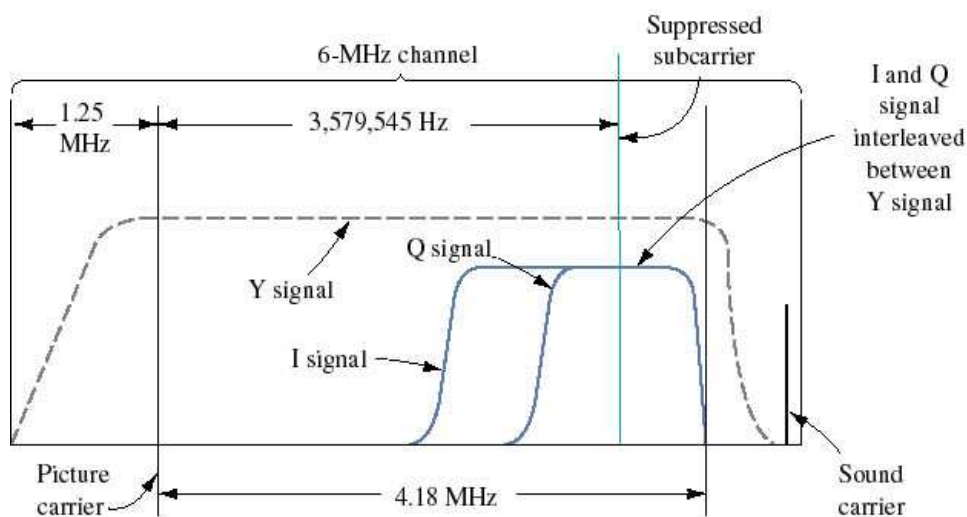
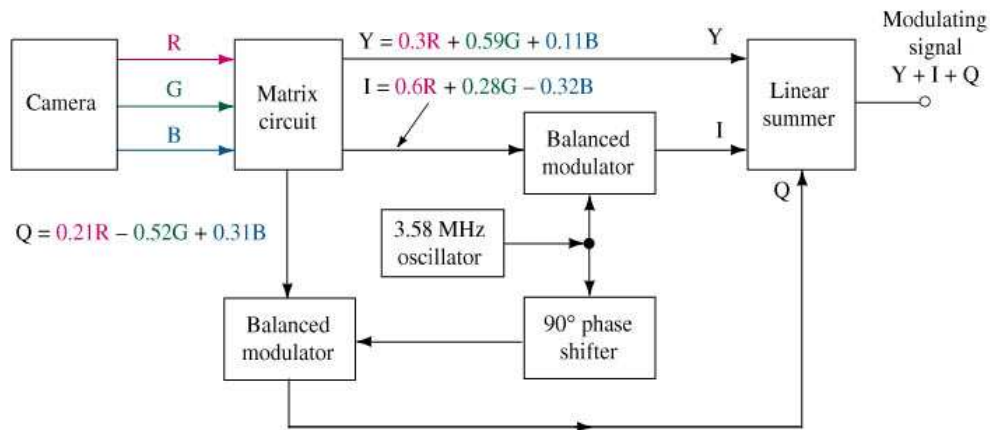

- If the broadcast is black and white only, the colour burst is omitted and the phase locked loop phase detector will produce a large dc output. This is detected and used to switch off the I and Q signal bandpass amplifier “colour killer”. This is to prevent any signal out of the Chroma circuits during a monochrome broadcast.
- A defective colour killer results in coloured noise called “confetti” on the screen of a colour TV receiver during a black and white transmission. The confetti looks like snow but with larger spots in colour

Question (3)

(18 Marks)

- a. Compare between TDMA and CDMA multiple access techniques. (3 marks)
- **TDMA** systems use digital technology to divide the radio spectrum by time so that each RF carrier is shared by several users. This multiplies system capacity. The RF carrier is divided into units of time called **frames**. Each frame is further divided into **time slots**. Each user is assigned a time slot (or slots) in every time frame. Once time slots are assigned, they remain dedicated until the caller hangs up or is handed-off to another channel.
 - **CDMA** supports many users on each RF carrier with relatively wide bandwidth, and distinguishes users by using digital codes rather than frequency or time. The same process that encodes speech signals also spreads them over a much wider bandwidth than other multiple access systems. IS-95 has 1.23 MHz CDMA carriers. CDMA transmissions appear more like noise than like information signals.
- b. The downlink C/N_o ratio in a direct broadcast satellite (DBS) system is estimated to be 80 dB-Hz. The specifications of the link are:

Satellite EIRP = 57 dBW, Downlink carrier frequency = 13 GHz
Data rate = 10 Mb/s, Required (E_b/N_o) at the receiving earth terminal = 12 dB
Distance of the satellite from the receiving earth terminal = 45,000 km

Calculate the minimum diameter of the dish antenna needed to provide a satisfactory TV reception, assuming that the dish has an efficiency of 60% and it is located alongside the home where the temperature is 300 K. For this calculation, assume that the operation of the DBS system is essentially downlink-limited. (6 marks)

Answer

For the downlink, the relationship between

$\left(\frac{C}{N_o}\right)$ and $\left(\frac{E_b}{N_o}\right)_{\text{req}}$, expressed in decibels, is described by

$$\left(\frac{C}{N_o}\right)_{\text{downlink}} = \left(\frac{E_b}{N_o}\right)_{\text{req}} + 10\log M + 10\log R \quad (1)$$

where M is the margin and R is the bit rate in bits/second.

Solving Eq. (1) for the the link margin in dB and evaluating it for the problem at hand, we get

$$10\log_{10} M = 80 - 12 - 10\log_{10}(10 \times 10^6) = -2\text{dB}$$

For the downlink budget, the equation for $\left(\frac{C}{N_0}\right)$, expressed in decibels, is as follows:

$$\left(\frac{C}{N_0}\right)_{\text{downlink}} = \text{EIRP} + \left(\frac{G_r}{T}\right)_{\text{dB}} - L_{\text{freespace}} - 10\log_{10}k$$

where k is Boltzmann's constant.

For a satisfactory reception at any situation, we consider additional losses due to rain etc. up to the calculated link margin of 5 dB. Hence, we may write

$$\left(\frac{C}{N_0}\right)_{\text{downlink}} = \text{EIRP} + \left(\frac{G_r}{T}\right)_{\text{dB}} - L_{\text{freespace}} - 10\log_{10}k - 10\log_{10}M(\text{dB}) \quad (2)$$

where

$$\text{EIRP} = 57 \text{ dBW}$$

$$L_{\text{freespace}} = \text{free-space loss}$$

$$= 92.4 + 20\log_{10}(13) + 20\log_{10}(45000)$$

$$= 196.6 \text{ dB}$$

$$10\log_{10}k = 228.6 \text{ dBK}$$

$$10\log_{10}M = -2 \text{ dB}$$

Using these values in Eq. (2) and solving for G_r/T , we get

$$\left(\frac{G_r}{T}\right)_{\text{dB}} = 80 - 57 + 196.6 - 228.6 - 2 = -11 \text{ dB}$$

$$G_r = -11 + 10\log_{10}(300)$$

$$= 13.77 \text{ dB}$$

The receiving antenna gain is given by

$$10\log_{10}G_r = 10\log_{10}\left(\frac{4\pi A\eta}{\lambda^2}\right)$$

For a dish antenna (circular) with diameter D , the area A equals $\pi D^2/4$. Thus,

$$10\log_{10}G_r = 20\log_{10}D + 20\log_{10}f + 10\log_{10}(\eta) + 20.4(\text{dB})$$

where D is measured in meters and f is measured in GHz. Solving for the antenna diameter for the given system, we finally get

$$D_{\text{min}} = 0.05 \text{ meters}$$

c. State if the following statements are (✓) or (✗) and justify your answer ‘Note: Negation is not the answer’: (3 marks)

1. (✗) **Correct:** Cellular radio systems consist of an array of hexagonal cells with a base station located at the center of each cell.
2. (✗) **Correct:** The mobile switching center ‘MSC’ handles the interface between the cellular radio system and the public switched telephone network ‘PSTN’.
3. (✗) **Correct:** The frequency reuse factor within a TDMA network is 1/7, while that of a CDMA network is one.

d. Discuss the following terms: 1. Rake Receiver 2. Cell Splitting 3. Handoff (6 marks)

Rake Receiver

- The rake receiver is a CDMA feature that turns what is a problem in other technologies into an advantage for CDMA. It's multiple receivers in one. It identifies the 3 strongest multi-path signals and combines them to produce one very strong signal. It uses multipath to reduce the power the Tx must send. Both the mobile and the BTS use rake receivers

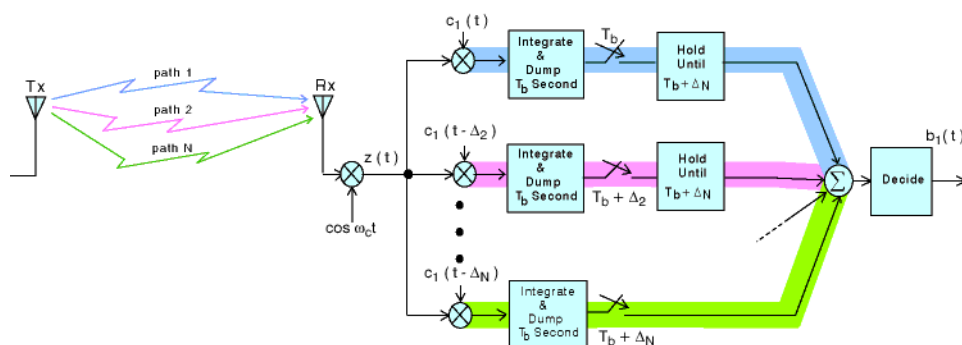

Cell Splitting

Cell splitting is used to handle the additional growth in traffic within a particular cell. A single cell contains a number of smaller cells called *microcells*. Sectorizing cells reduce interference with other sectors using the same frequencies. A 3-sector cell site uses three directional antennas with propagation of 120 degrees.

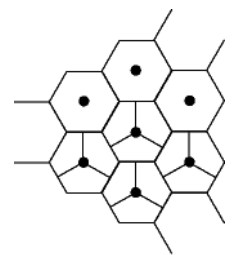

Hand off

When the SNR falls below a specified threshold ‘when the MS leaves its cell or when the radio channel fades, it is switched to another BS. This switching process is called “*handover* or *handoff*” to move the MS from one BS to another during a call in without an interruption of service.